

1.00mm Height 1502 Package Side View
White Chip LED
Technical Data Sheet

Part No.: DL-TOP020W85M-1W120

Double Light

◆ Features:

1. White SMT package.
2. Package: 3.8*1.0*0.6mm
3. Side view white LED.
4. Wide viewing angle.
5. Lead frame package with individual 2 pins.
6. Compatible with automatic placement equipment.
7. Compatible with infrared and vapor phase reflow solder process.
8. The product itself will remain within RoHS compliant Version.

◆ Descriptions:

1. Due to the package design, the 020 SMD LED has wide viewing angle, low power consumption and white LEDs are devices which are materialized by combing blue LEDs and special phosphors. This feature makes the LED ideal for light guide application.
2. The 020 SMD LEDs much smaller than lead frame type components, thus enable smaller board size, higher packing density, reduced storage space and finally smaller equipment to be obtained.
3. The white LED which was fabricated using a blue LED and a phosphor, and the phosphor is excited by blue light and emits yellow fluorescence the mixture of blue light and yellow light results in white emission.
4. Utilizing advanced InGaN chip technology.
5. Besides, lightweight makes them ideal for miniature applications, etc.

◆ Applications:

1. Automotive: Backlighting in dashboard and switch.
2. Telecommunication: Indicator and backlighting in telephone and fax.
3. Flat backlight for LCD, switch and symbol.
4. Indoor signboard use.
5. LCD Back Light.
6. Indicators.
7. Illuminations.
8. Mobile phones.
9. General use.

Double Light

◆ Package Dimension:

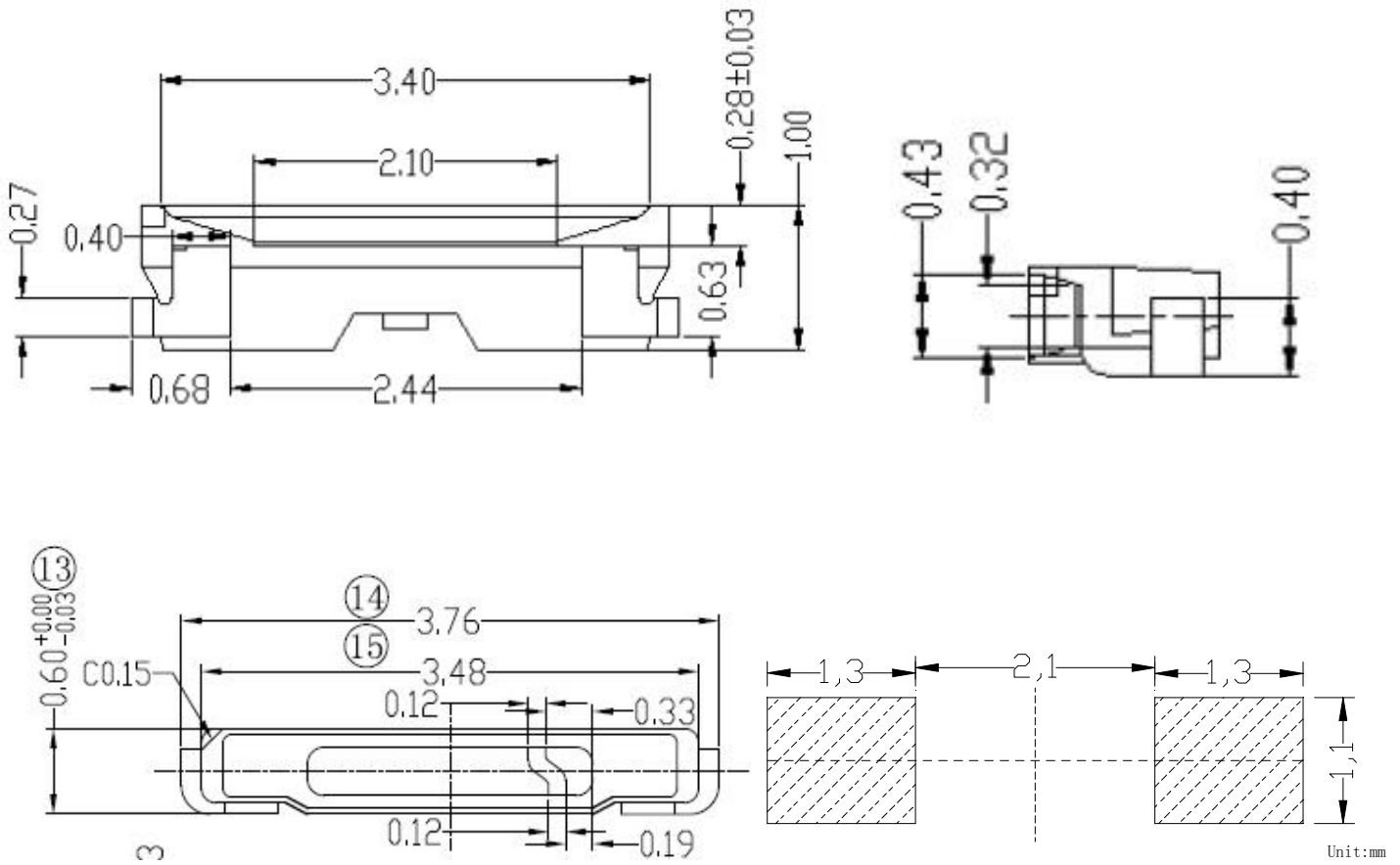

Part No.	Chip Material	Lens Color	Source Color
DL-TOP020W85M-1W120	InGaN	Yellow Diffused	White

Notes:

1. All dimensions are in millimeters (inches).
2. Tolerance is ± 0.10mm (.004") unless otherwise specified.
3. Specifications are subject to change without notice.

Double Light

◆ Absolute Maximum Ratings at Ta=25°C

Parameters	Symbol	Max.	Unit
Power Dissipation	PD	95	mW
Peak Forward Current (1/10 Duty Cycle, 0.1ms Pulse Width)	IFP	100	mA
Forward Current	IF	30	mA
Reverse Voltage	VR	5	V
Derating Linear From 25°C		0.3	mA/°C
Electrostatic Discharge (HBM)	ESD	1000	V
Operating Temperature Range	Topr	-40°C to +80°C	
Storage Temperature Range	Tstg	-40°C to +85°C	
Soldering Temperature	Tsld	Reflow Soldering: 260°C for 5 Seconds Hand Soldering: 350°C for 3 Seconds	

Electrical Optical Characteristics at Ta=25°C

Parameters	Symbol	Min.	Typ.	Max.	Unit	Test Condition
Luminous Intensity *	IV	2600	3000	---	mcd	IF=20mA (Note 1)
Viewing Angle *	2θ _{1/2}	---	120	---	Deg	IF=20mA (Note 2)
Chromaticity Coordinates	x	---	0.30	---		IF=20mA (Note 3)
	y	---	0.31	---		
Forward Voltage	VF	2.80	3.20	3.40	V	IF=20mA
Reverse Current	IR	---	---	10	μA	V _R =5V

Notes:

1. Luminous Intensity Measurement allowance is ± 10%.
2. θ_{1/2} is the off-axis angle at which the luminous intensity is half the axial luminous intensity.
3. It use many parameters that correspond to the CIE 1931 2°. X, Y, and Z are CIE 1931 2° values of Red, Green and Blue content of the measurement.

Double Light

◆ Typical Electrical / Optical Characteristics Curves

(25°C Ambient Temperature Unless Otherwise Noted)

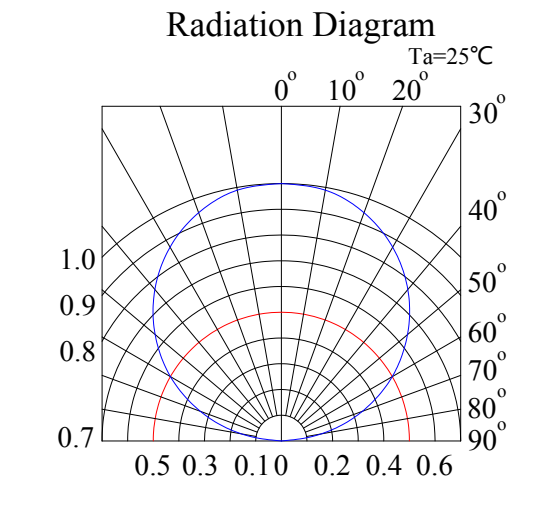
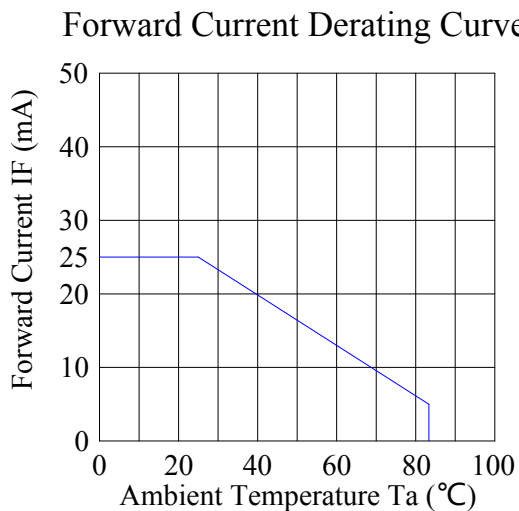
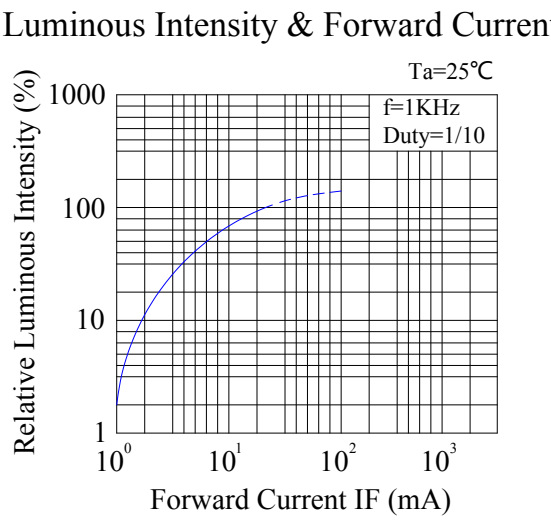
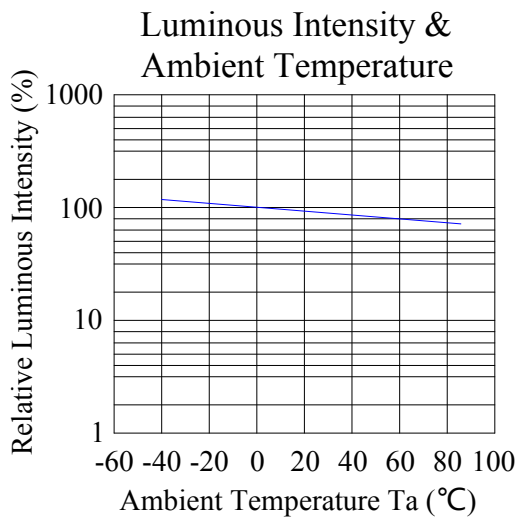
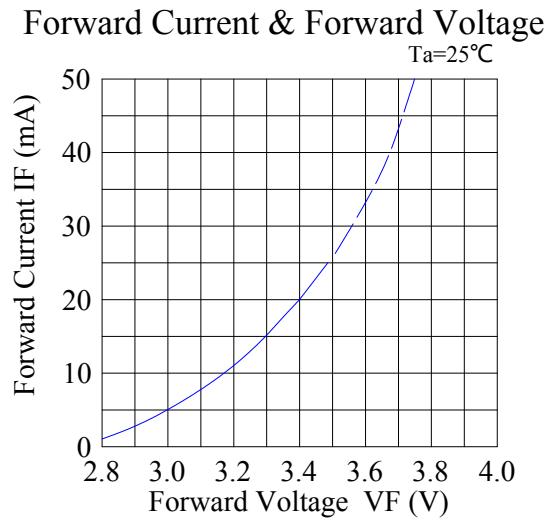
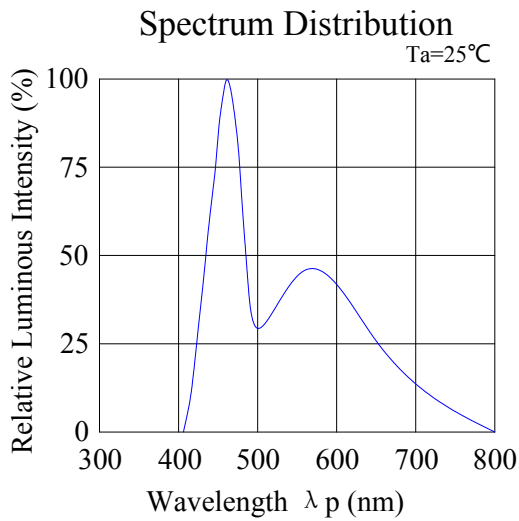

Double Light

CIE Chromaticity Diagram:

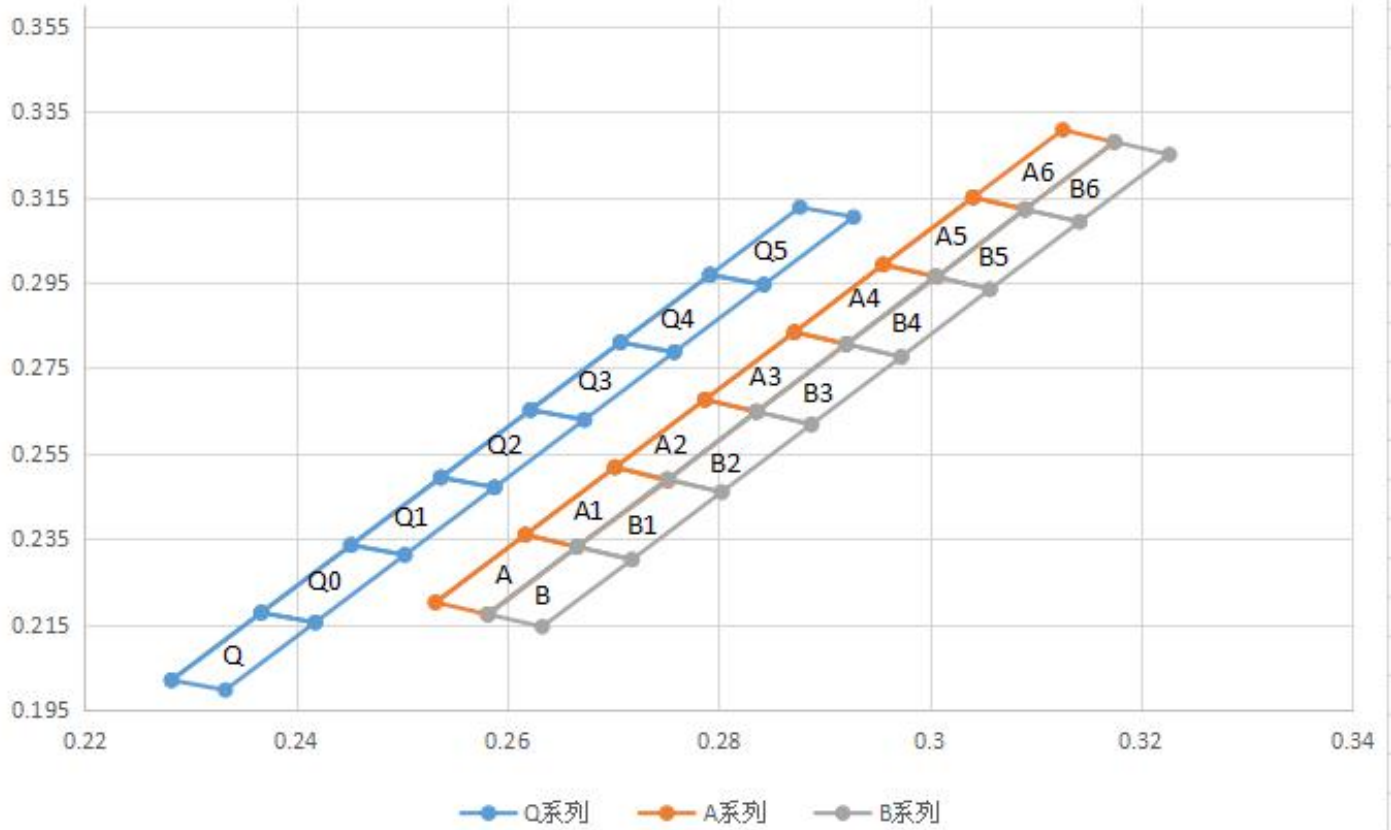

Chromaticity Coordinates Specifications for Bin Rank:(1)

BIN Code	X	Y	BIN Code	X	Y	BIN Code	X	Y
A5	0.2956	0.2992	A6	0.3041	0.3149	B	0.2582	0.2174
	0.3041	0.3149		0.3126	0.3307		0.2666	0.2332
	0.309	0.3121		0.3175	0.3278		0.2718	0.2302
	0.3007	0.2963		0.309	0.3121		0.2633	0.2145
B1	0.2666	0.2332	B2	0.2752	0.2489	B3	0.2836	0.2648
	0.2751	0.249		0.2836	0.2648		0.2921	0.2806
	0.2803	0.246		0.2888	0.2618		0.2973	0.2776
	0.2718	0.2302		0.2803	0.246		0.2888	0.2618
B4	0.2921	0.2806	B5	0.3007	0.2963	B6	0.309	0.3121
	0.3005	0.2964		0.309	0.3121		0.3175	0.3279
	0.3057	0.2934		0.3142	0.3092		0.3227	0.3249
	0.2973	0.2776		0.3057	0.2934		0.3142	0.3092

Double Light

Chromaticity Coordinates Specifications for Bin Rank:(2)

BIN CODE	Min (mcd)	Max (mcd)	Min (Lm)	Max (Lm)	Test Condition
26	2600	2700	7.6	7.9	If=20mA
27	2700	2800	7.9	8.2	
28	2800	2900	8.2	8.5	
29	2900	3000	8.5	8.8	
30	3000	3100	8.8	9.1	
31	3100	3200	9.1	9.4	
32	3200	3300	9.4	9.7	
33	3300	3400	9.7	10	
34	3400	3500	10	10.3	
35	3500	3600	10.3	10.6	
36	3600	3700	10.6	10.9	

Chromaticity Coordinates Specifications for Bin Rank:(3)

BIN CODE	Min	Max	Unit	Test Condition
V28	2.8	2.9	V	If=20mA
V29	2.9	3.0		
V30	3.0	3.1		
V31	3.1	3.2		
V32	3.2	3.3		
V33	3.3	3.4		

Double Light

◆ Reliability Test Items And Conditions:

The reliability of products shall be satisfied with items listed below:

Confidence level: 90%.

LTPD: 10%.

1) Test Items and Results:

No.	Test Item	Test Hours/Cycles	Test Conditions	Sample Size	Ac/Re
1	Resistance to Soldering Heat	6 Min	Tsld=260±5°C, Min. 5sec	25pcs	0/1
2	Thermal Shock	300 Cycles	H: +100°C 5min f 10 sec L: -10°C 5min	25pcs	0/1
3	Temperature Cycle	300 Cycles	H: +100°C 15min f 5min L: -40°C 15min	25pcs	0/1
4	High Temperature Storage	1000Hrs.	Temp: 100°C	25pcs	0/1
5	DC Operating Life	1000Hrs.	IF=20mA	25pcs	0/1
6	Low Temperature Storage	1000Hrs.	Temp: -40°C	25pcs	0/1
7	High Temperature/ High Humidity	1000Hrs.	85°C/85%RH	25pcs	0/1

2) Criteria for Judging the Damage:

Item	Symbol	Test Conditions	Criteria for Judgment	
			Min	Max
Forward Voltage	VF	IF=20mA	---	F.V.*)×1.1
Reverse Current	IR	VR=5V	---	F.V.*)×2.0
Luminous Intensity	IV	IF=20mA	F.V.*)×0.7	---

*) F.V.: First Value.

Double Light

◆ Reel Dimensions:

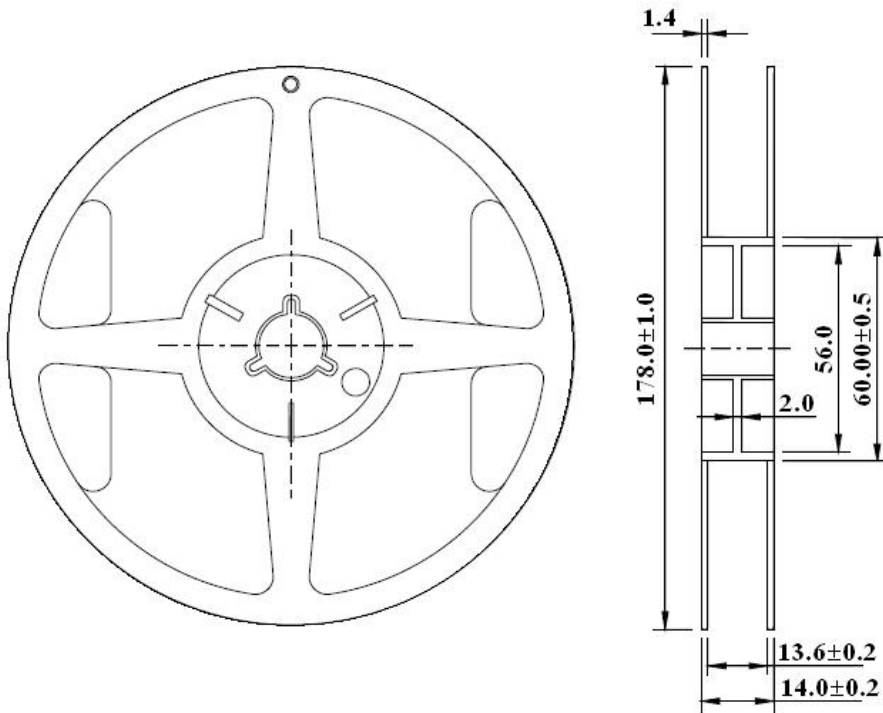

Carrier Tape Dimensions:

Loaded quantity 3000/4000PCS per reel.

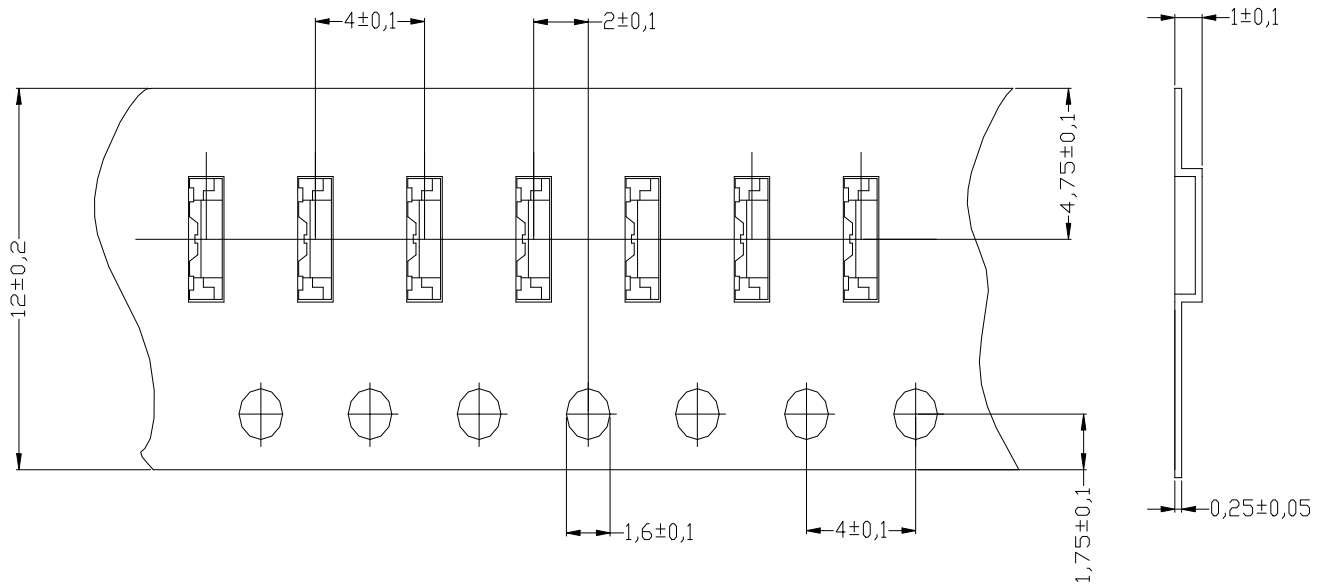

Double Light

◆ Please read the following notes before using the product:

1. Over-current-proof

Customer must apply resistors for protection, otherwise slight voltage shift will cause big current change (Burn out will happen).

2. Storage

2.1 Do not open moisture proof bag before the products are ready to use.

2.2 Before opening the package, the LEDs should be kept at 30°C or less and 90%RH or less.

2.3 The LEDs should be used within a year.

2.4 After opening the package, the LEDs should be kept at 30°C or less and 70%RH or less.

2.5 The LEDs should be used within 168 hours (7 days) after opening the package.

2.6 If the moisture adsorbent material (silica gel) has fabled away or the LEDs have exceeded the storage time, baking treatment should be performed using the following conditions. Baking treatment: 60±5°C for 24 hours.

3. Soldering Condition

3.1 Pb-free solder temperature profile.

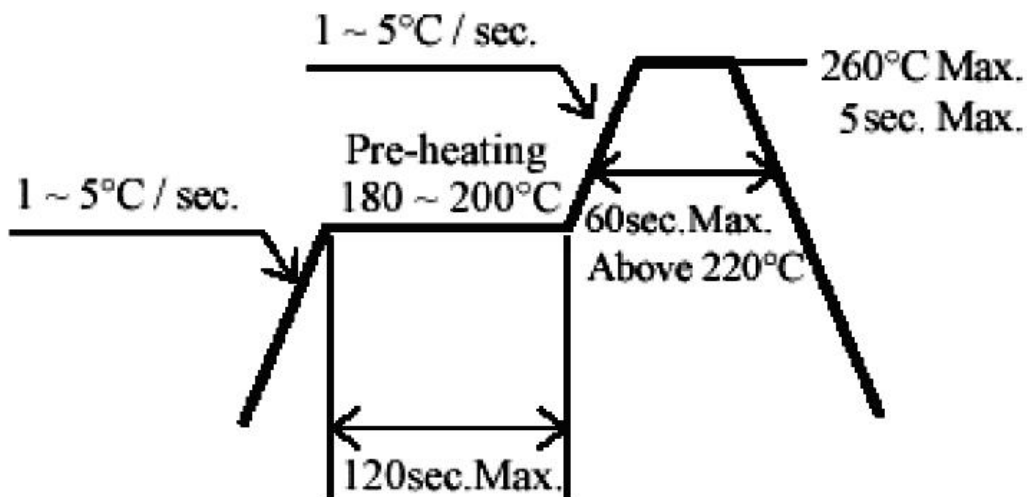

3.2 Reflow soldering should not be done more than two times.

3.3 When soldering, do not put stress on the LEDs during heating.

3.4 After soldering, do not warp the circuit board.

4. Soldering Iron

Each terminal is to go to the tip of soldering iron temperature less than 260°C for 5 seconds within once in less than the soldering iron capacity 25W. Leave two seconds and more intervals, and do soldering of each terminal. Be careful because the damage of the product is often started at the time of the hand solder.

5. Repairing

Repair should not be done after the LEDs have been soldered. When repairing is unavoidable, a double-head soldering iron should be used (as below figure). It should be confirmed beforehand whether the characteristics of the LEDs will or will not be damaged by repairing.

Double Light

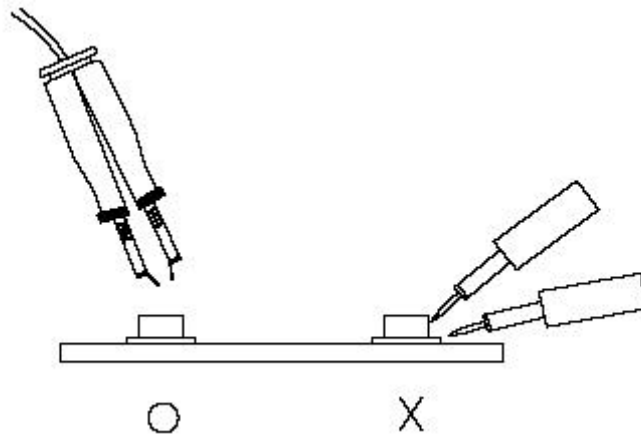

6. Caution in ESD

Static Electricity and surge damages the LED. It is recommended to use a wrist band or anti-electrostatic glove when handling the LED. All devices, equipment and machinery must be properly grounded.